

SALICE

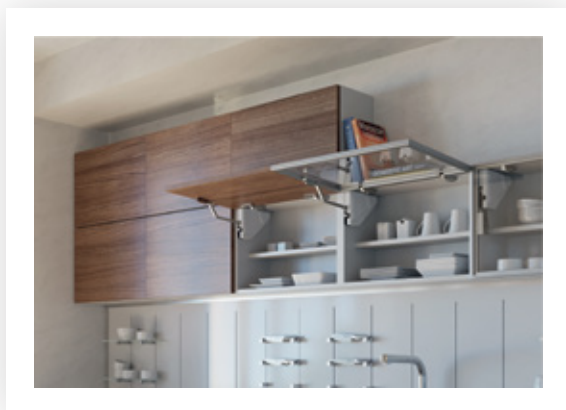

Pomembno

Clip-on namestitev vrat brez orodja

3-dimenzionalna nastavitev vrat

Kot odpiranja se regulira od 80° in 95°

Izjemno udobno odpiranje po zaslugi vzmetnega mehanizma

Vgrajen nastavljen blažilnik zapiranja omogoča tiho in nežno zapiranje

Načrt za pritrnitev pritrnilca na lesena vrata

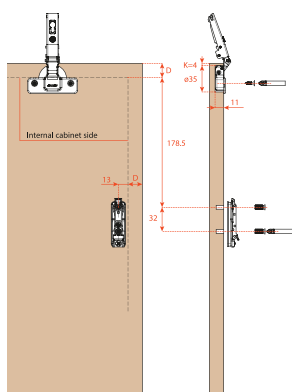

*D - prekrivanje vrat na stranico

Načrt za pritrnitev pritrnilca na ALU ozek okvir

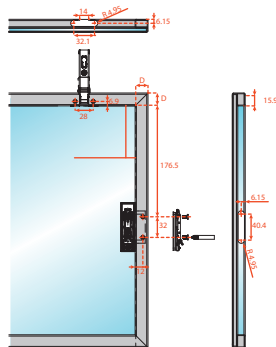

*D - prekrivanje vrat na stranico

Pritrditev mehanizma FLAP na stranico

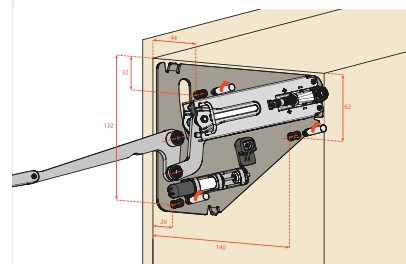

Pritrditev vrat na mehanizem FLAP

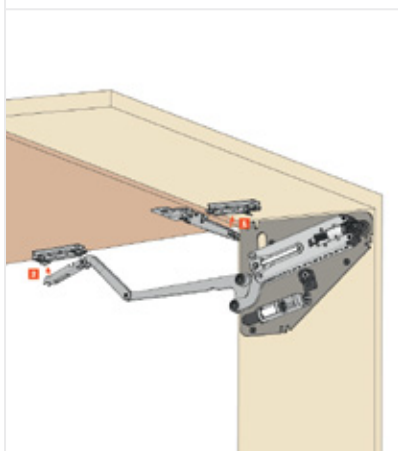

Evolift FLAP – LAŽJI / desni

DSN9D

Evolift FLAP – LAŽJI / levi

DSN9S

Evolift FLAP – MOČNEJŠI / desni

FSN9D

Evolift FLAP – MOČNEJŠI / levi

FSN9S

Evolift FLAP – pok. kapa BELA / desna

SRDM78AQ

Evolift FLAP – pok. kapa BELA / leva

SRS78AQ

Evolift FLAP – pok. kapa TITAN / desna

SRDM78AL

Evolift FLAP – pok. kapa TITAN / leva

SRS78AQ

SALICE

Izmakni varovalo

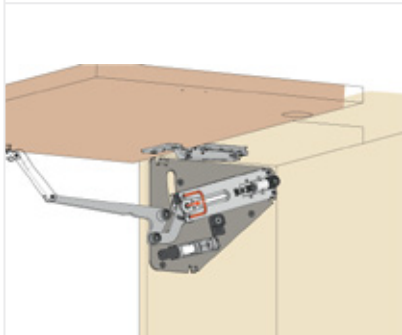

Regulacija jakosta mehanizma FLAP

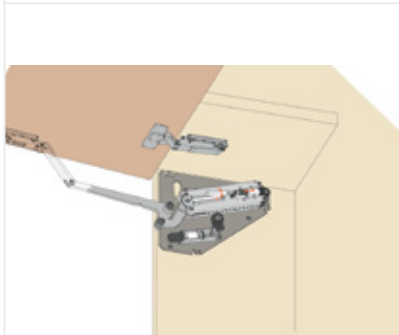

Regulacija mehkega zapiranja FLAP

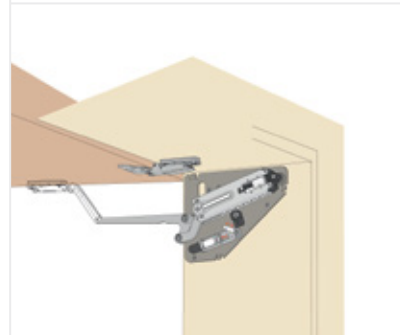

Regulacija omejitve dviga vrat (80° - 95°)

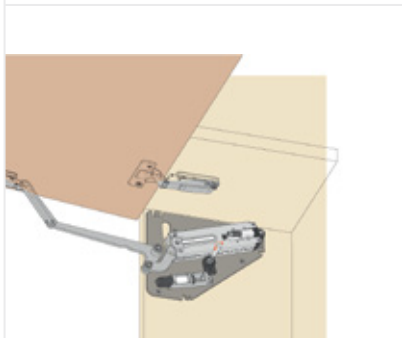

Dimenzije mehanizma FLAP



Tabela jakosti pri uporabi dveh mehanizmov FLAP



Tabela jakosti pri uporabi enega mehanizma FLAP

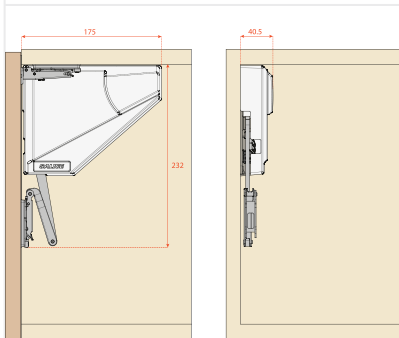

Teža vrat

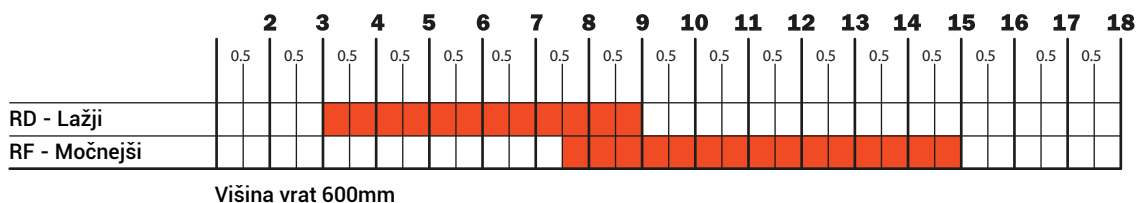
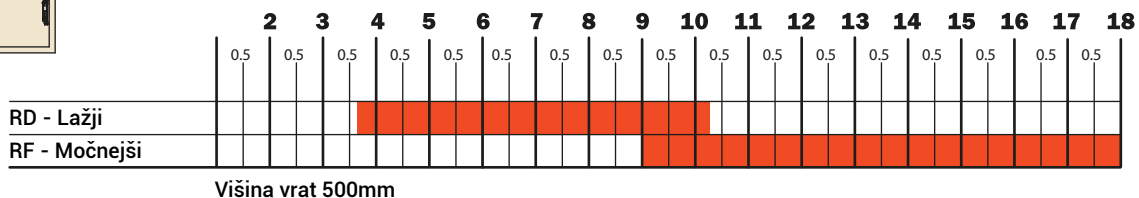
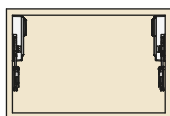
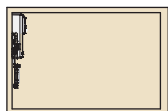
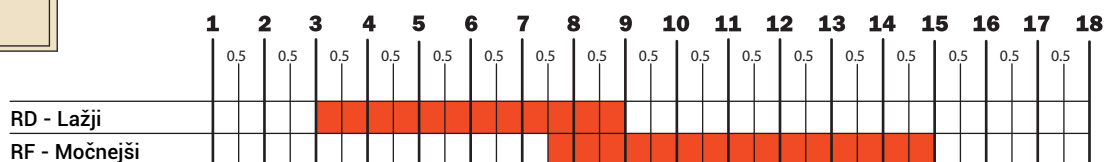

Višina vrat 300mm

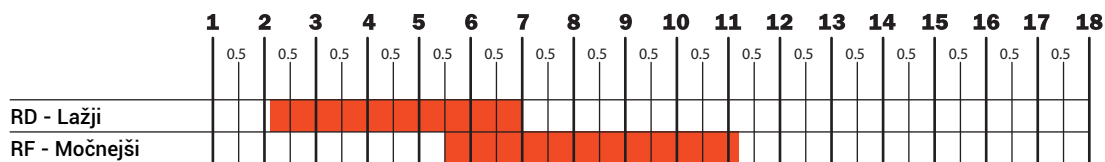

Višina vrat 400mm

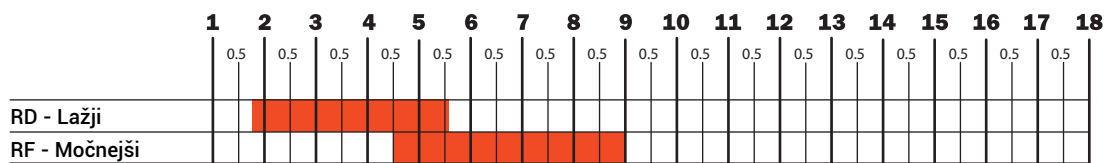

Višina vrat 500mm

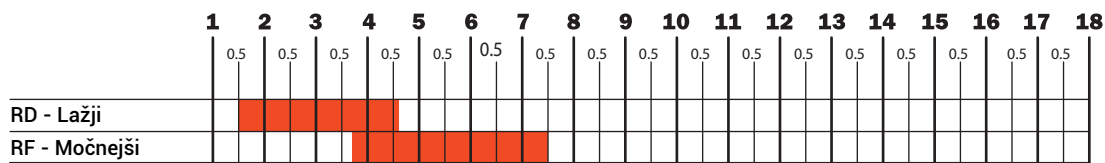

Višina vrat 600mm