

INVISACTA IN230

Stavbno okovje in tesnila
/ Spone za vrata

OTLAV



Pomembno

Skrita spona IN230 nosilnosti 60 kg

Art. IN-230120V702 (ALU)

Art. IN-2301209P02 (Bela)

Art. IN-2301209N02 (Črna)

Pokrivne kapice

Art. IN-GC230010J120 (ALU)

Art. IN-GC2300109P02 (Bela)

Art. IN-GC2300109N02 (Črna)

Navodila za montažo

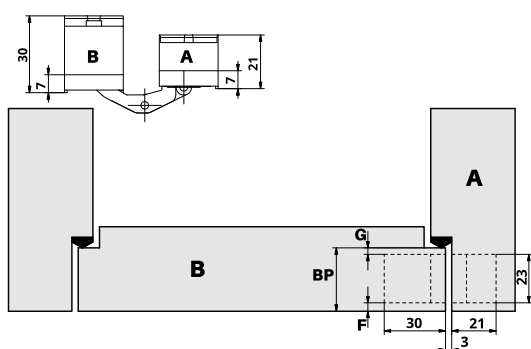
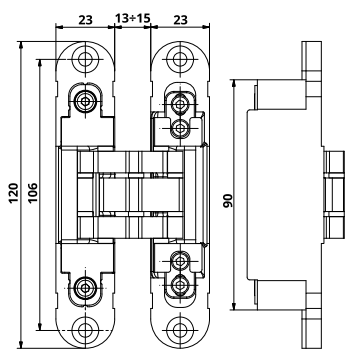

BP	30	31	32	33	34	35	36	37	38	39	40
F	4	4	4	4	4	4	4	4	4	4	4
G	5	4	5	6	7	8	9	10	11	12	13

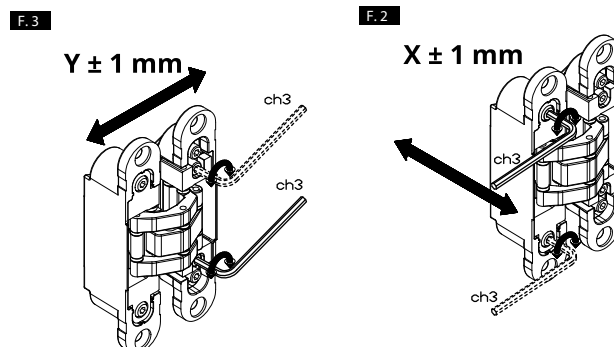
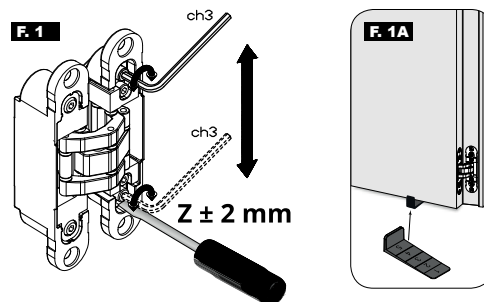
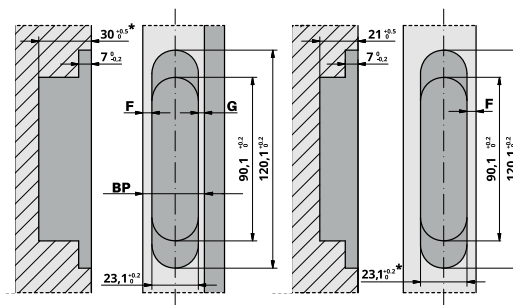

OTLAV

Tehnični podatki

Teža vrat do 60 kg. - skrita spona IN230

Višina vrat mm.	2700	4	4	4	4	4	4	5	5
	2400	4	4	4	4	4	4	4	5
	2300	4	4	4	4	4	4	4	5
	2200	3	3	3	3	3	4	4	5
	2100	2	2	2	3	3	3	4	5
	2000	2	2	2	3	3	3	4	2
	1900	2	2	3	3	3	2	2	3
	1800	2	3	3	3	2	2	3	3
	1200	2	3	3	3	NA	NA	NA	NA
	800	3	3	3	NA	NA	NA	NA	NA
		600	800	900	1000	1050	1100	1150	1200

Širina vrat mm.

X	Priporočeno število spon
2	Za zamenjavo spone višje nosilnosti
3	Za zamenjavo spone višje nosilnosti
NA	Kontaktirajte tehnično pomoč

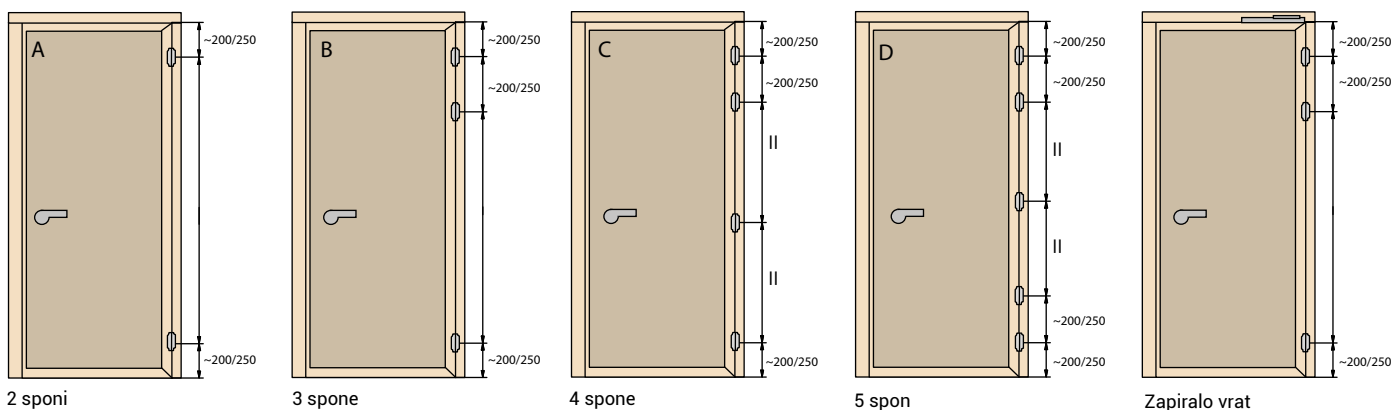

Tabela OTLAV spon glede na max. nosilnost	
Kapaciteta	Model
30 kg.	IN232
40 kg.	IN235, IN301, IN305
60 kg.	IN230, IN300
80 Kg.	IN303
120 kg.	IN310

Lahko se uporabi z Invisacto IN230 vendar glede na tabelo po uporabi števila spon, se nosilnost zmanjša za 20%.