



# ART K100

GUIDE SIGE - SIGE SLIDES - COULISSES SIGE - GUÍAS SIGE

REV 00.2022

FOIST00198

SIGE S.P.A.

60020 POLVERIGI (AN) ITALY

TEL +39 071 90 90 000 R.A. - FAX +39 071 90 90 804

WWW.SIGE-SPA.IT INFO@SIGE-SPA.IT

PRODOTTO ED ASSEMBLATO IN ITALIA / MADE AND ASSEMBLED IN ITALY / FABRIQUÉ ET ASSEMBLÉ EN ITALIE / HECHO Y MONTADO EN ITALIA

## CARATTERISTICHE • FEATURES • CARACTÉRISTIQUES • CARACTERÍSTICAS

Telaio estraibile, con guide a chiusura ammortizzata e distanziali regolabili.

Pull out frame, slides with soft closing and adjustable spacers.

Châssis coulissant, avec glissières amortisseur et entretoises réglables.

Marco estraibile, con guías amortiguada y espaciador ajustable.

## MINUTERIA INTERNA • FITTINGS • FERRURE • FERRETERIA

N°4 M5x10 T.c.e.i. Vite / Screw / Vis / Tornillo

N°8 6,3x14 T.c. Euroviti / Euro screw / Euro vis / Tornillo euro

N°1 Chiave esagonale / Key exagonal / Clés exagonale / Llave hexagonal

## COMPONENTI • PARTS • COMPOSANTS • COMPONENTES

A. N°1 Telaio / Frame / Châssis / Marco

B. N°1 Distanziale laterale Sx / Lateral spacer Sx / Entretoise latérale Sx / Distanciadores lateral Sx

C. N°1 Distanziale laterale Dx / Lateral spacer Dx / Entretoise latérale Dx / Distanciadores lateral Dx

D. N°1 Set guide / Slide kit / Kit Coulisses / Kit guías

E. N°1 L.2.5m Guarnizione gomma / Rubber gasket / Joint en caoutchouc / Junta de goma

## UTENSILERIA • TOOLS • OUTILS • INSTRUMENTOS



## MANUTENZIONE • MAINTENANCE • ENTRETIEN • MANTENIMIENTO

Pulire con un panno morbido ed asciutto. Evitare l'uso di solventi e/o abrasivi.

Clean with a soft, dry cloth. Avoid using solvents or abrasive.

Nettoyez avec un chiffon sec et doux. N'utilisez pas aucun solvant ou produit abrasif.

Limpia con paño suave y seco. Evitar el uso de solventes y/o abrasivos.

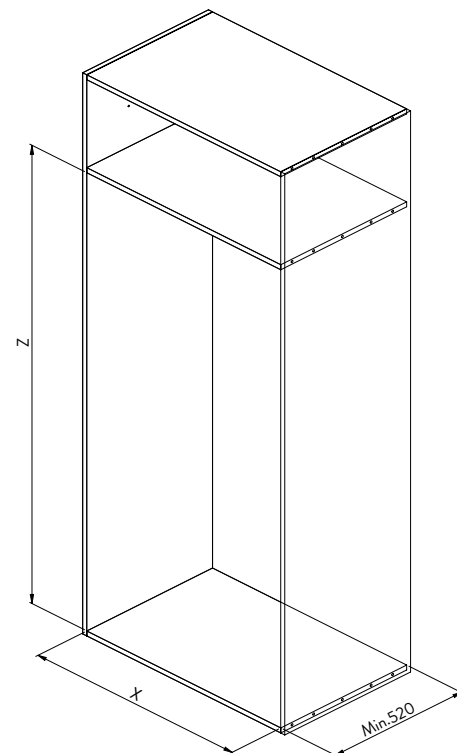

| L. CABINET | X MIN | X MAX |
|------------|-------|-------|
| 450        | 400   | 418   |
| 500        | 450   | 468   |
| 600        | 550   | 568   |
| 800        | 750   | 768   |
| 900        | 850   | 868   |
| 1000       | 950   | 968   |
| 1200       | 1150  | 1168  |

| Z | H 58    | H 128   |
|---|---------|---------|
|   | min 250 | min 320 |

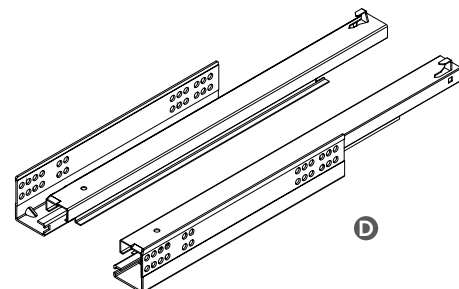
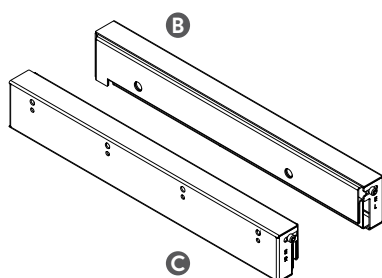
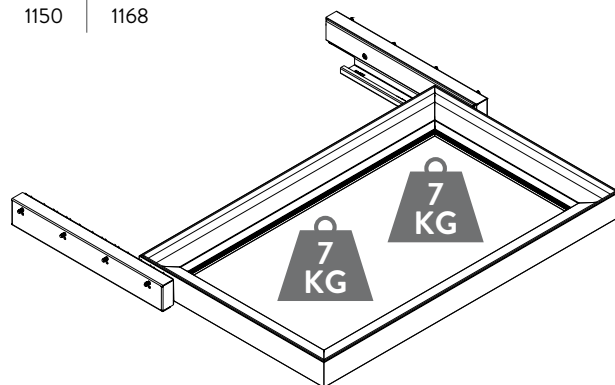
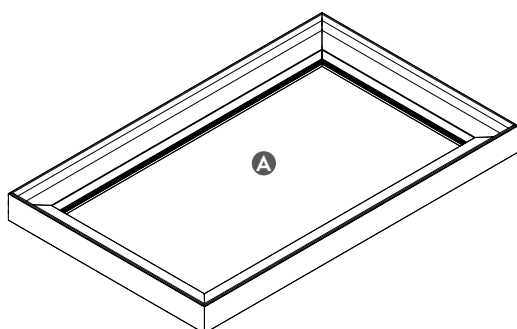

**1****N°4 M5x10**

Scomporre i distanziali (B e C) ed avvitare le guide nei fori indicati.  
 Disassemble the spacers (B and C) and screw the guides in the indicated holes.

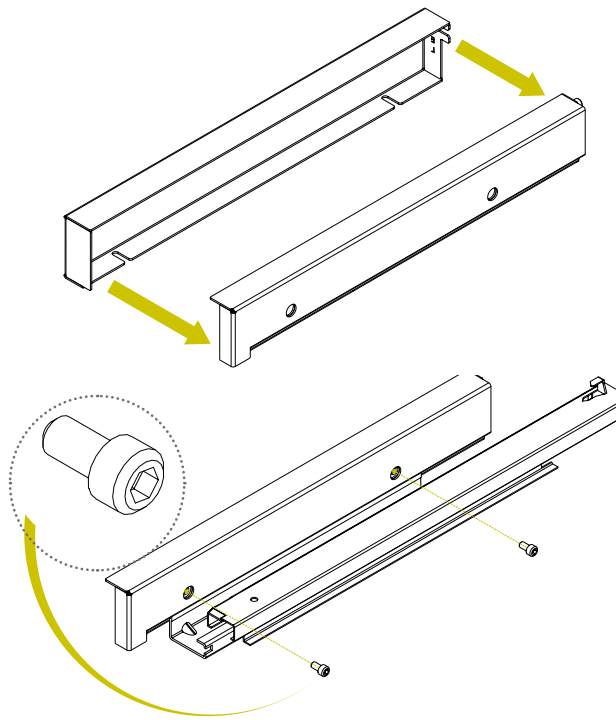

Démonter les entretoises (B et C) et visser les guides dans les trous indiqués.  
 Desmontar los distanciadores (B y C) y atornillar las guías en los agujeros indicados.

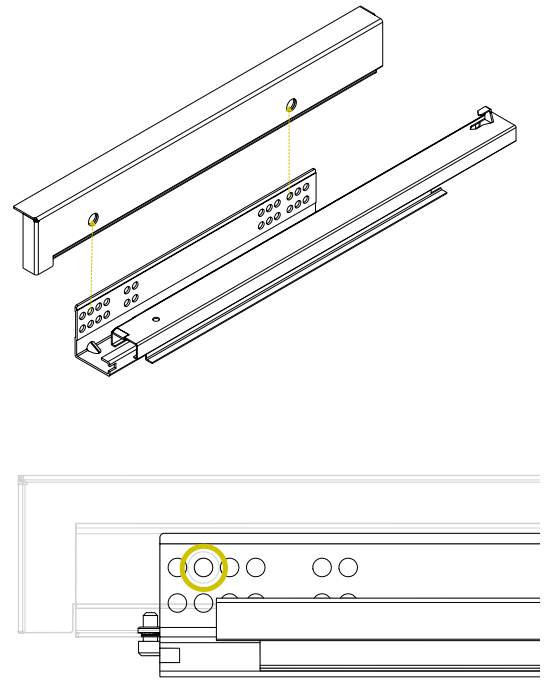
**N°8 6.3x14****2**

Preforare i fianchi del mobile (ø5x13) alle quote indicate ed avvitare i distanziali.  
 Pre-drill the sides of the cabinet (ø5x13) at the indicated dimensions and screw the spacers.

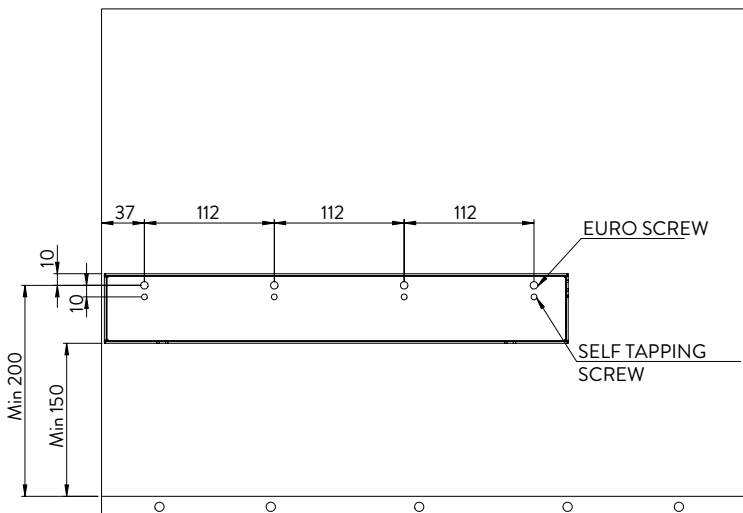

Pré-percer les côtés du meuble (ø5x13) aux cotes indiquées et visser les entretoises.  
 Pretaladre los lados del gabinete (ø5x13) en las dimensiones indicadas y atornille los espaciadores.

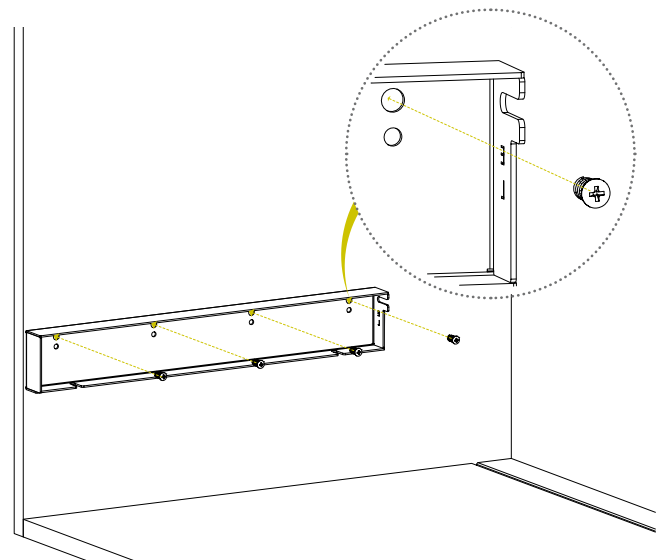

3

Posizionare il distanziale all'interno del profilo.  
Place the spacer inside the profile.

Placez l'entretoise à l'intérieur du profil.  
Coloque el espaciador dentro del perfil.

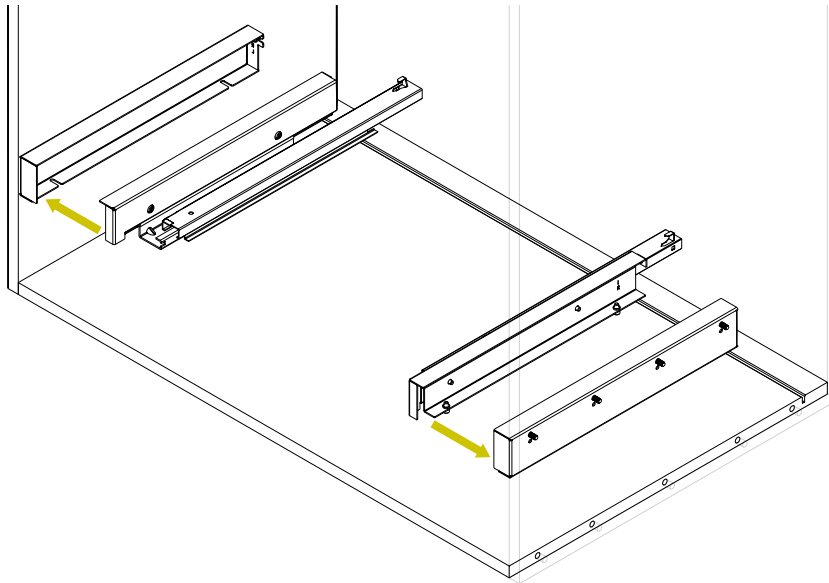

4

Inserire la guarnizione in gomma all'interno dell'apposita scanalatura ed agganciare il telaio alle guide come mostrato.  
Insert the rubber gasket inside the groove and hook the frame to the guides as shown.

Insérez le joint en caoutchouc à l'intérieur de la rainure et accrochez le cadre aux guides comme indiqué.  
Inserte la junta de goma dentro de la ranura y enganche el marco a las guías como se muestra.

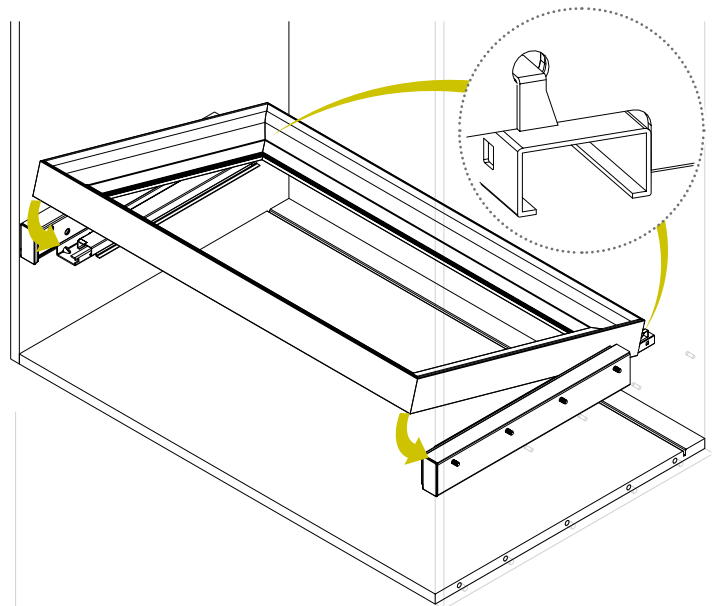
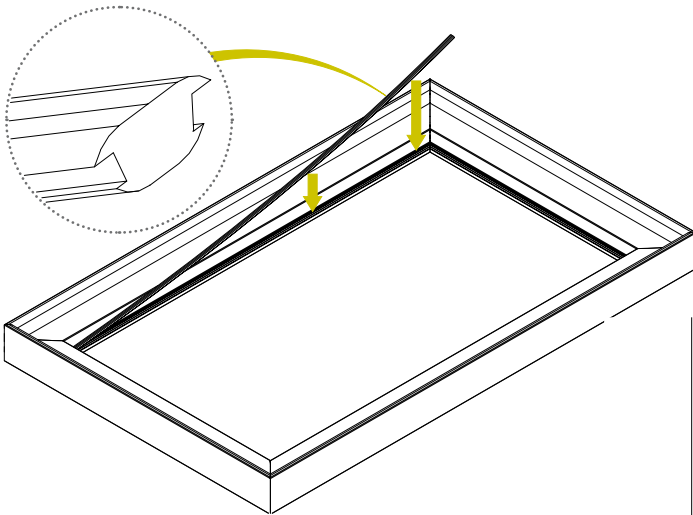

CLICK!

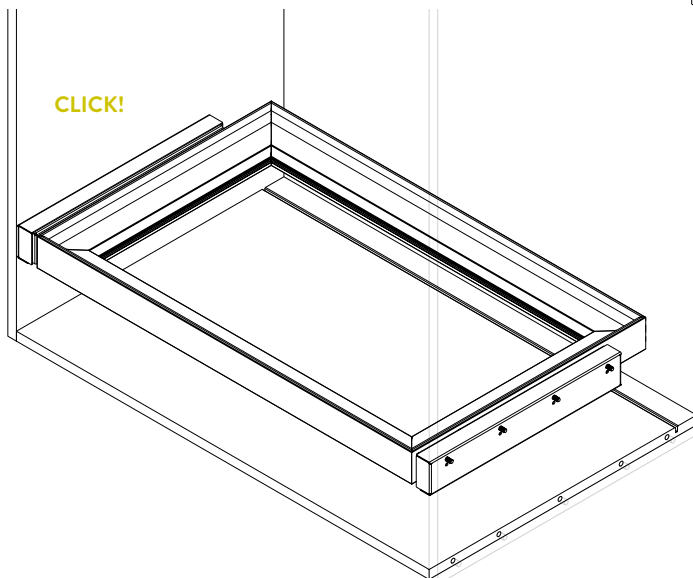

5

Regolare entrambi i distanziali alla stessa distanza, infine serrare le 6 viti (2 posteriori e 4 inferiori).

Adjust both spacers to the same distance, then tighten the 6 screws (2 rear and 4 lower).

Réglez les deux entretoises à la même distance, puis serrez les 6 vis (2 arrière et 4 inférieures).

Ajuste ambos espaciadores a la misma distancia, luego apriete los 6 tornillos (2 traseros y 4 inferiores).

